

Note: system has internal resettable fuse

Fuse

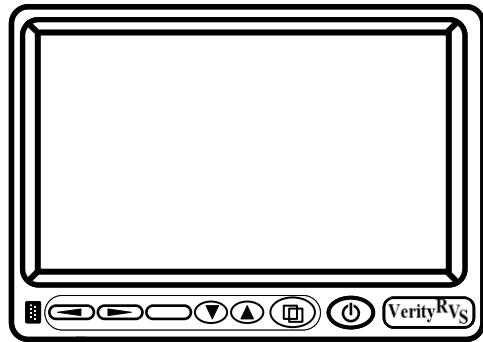

Note: SAE J1292 "suggests" ground wire be white in trucking. We have chosen to utilize a black wire for commonality across our industries served.

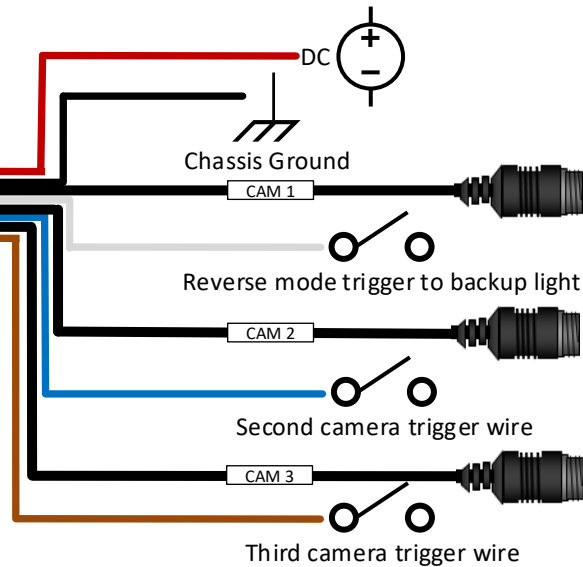

20m – 65 ft. female to male camera cable part# CB020



Includes our ADD25F Heavy Duty Mount



Verity Rear Vision Camera Part Number C001C

Wire Connection Key with waterproof 4-pin camera connectors

Red wire to Ignition hot (+) 10-24v. DC (waterproof fuse) DC

Black wire to GND. (-)

White trigger for camera 1 / **Black 4-pin (Cam 1)** - Camera 1 Rear

Blue trigger for camera 2 / **Black 4-pin (Cam 2)** – Optional Camera

Brown trigger for camera 3 / **Black 4-pin (Cam 3)** – Optional Camera

NOTICE

Diagram is for reference purpose only
Subject to change without notice. Not to Scale

Drawing by:
Bill V.
6/2018

**Wiring layout for
Systems SM07C "C" Series
Three Camera Input System**